



**UK** Gibbs House  
 Kennel Ride, Ascot  
 Berkshire, SL5 7NT UK  
 www.lighthouse-tech.com  
 voice +44 1344 620 838  
 fax +44 1344 876 136  
 sales@Lighthouse-tech.com

**THE NETHERLANDS** P.O.Box 597  
 NL-2130 AN Hoofddorp  
 The Netherlands  
 www.lighthouse-tech.com  
 voice +31 653 870 195  
 fax +31 252 412 736  
 sales@Lighthouse-tech.com

**USA** 1011 Passport Way  
 Cary, NC 27513 USA  
 www.lighthouse-tech.com  
 voice +1 919 677 0327  
 fax +1 919 677 1732  
 sales@Lighthouse-tech.com

**CANADA** #504-1001 West Broadway  
 Vancouver, BC  
 Canada V6H 4B1  
 www.lighthouse-tech.com  
 voice +1 604 261 0361  
 fax +1 604 261 6043 sales@Lighthouse-tech.com

**HONG KONG** 5th Floor, HKPC Bldg.  
 78 Tat Chee Avenue  
 Kowloon, Hong Kong  
 www.lighthouse-tech.com  
 voice +852 2192 1688  
 fax +852 2423 1092  
 sales@Lighthouse-tech.com

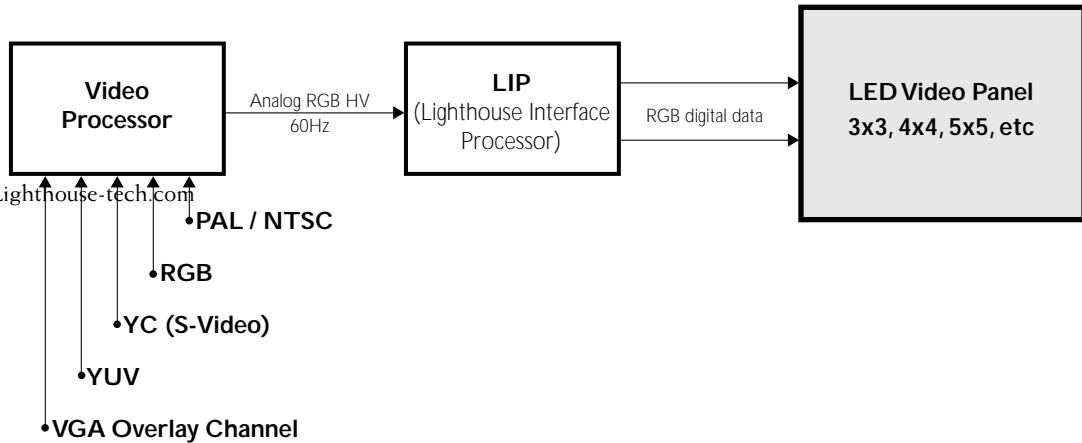
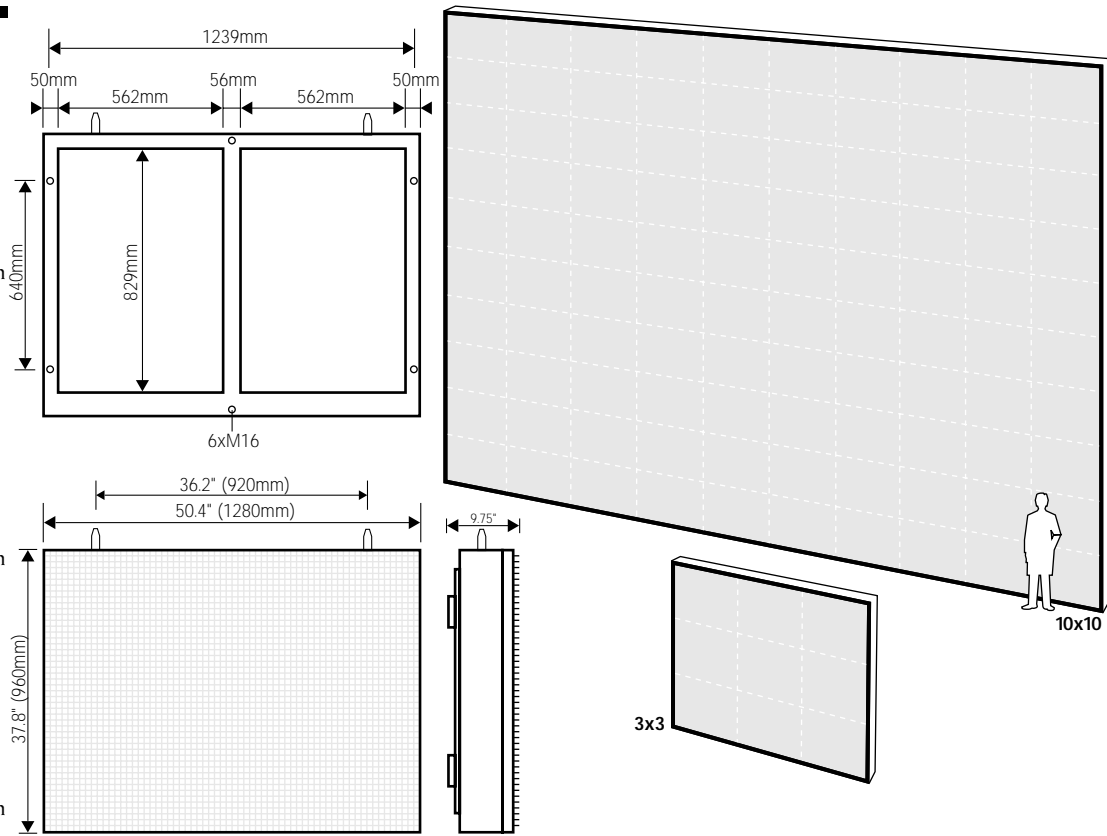

dimension / specification	LVP501	LVP502	LVP503
• brightness	4000 nits	5700 nits	5000 nits
• viewing angle horizontal (50% brightness)	90 degree	140 degree	160 degree
• average power	600 W	400 W	600 W
• maximum power	1800 W	1200 W	1800 W
• panel weight	264 lb (120kg)	198 lb (90 kg)	198 lb (90 kg)
• display refresh rate	1000 Hz typical	1000 Hz typical	4000 Hz typical
• panel length	50.4" (1280 mm)		
• panel height	37.8" (960 mm)		
• panel depth	9.75" (248 mm)		
• pixel pitch	0.787" (20 mm)		
• pixel	232 dots per sq ft (2500 dots per sq m)		
• colors	16.7 million		
• gray scale	256 for each color		
• video display refresh	50/60 frames per second		
• video input	RGB HV, composite, YC, YUV, RGB, VGA overlay, RGBS		
• voltage	90 - 260 V ac, 50Hz/60Hz		
• lifetime	> 50,000 hours		